



GEMINI
Filling | Dispensing | Cleaning

GemiFill S

Semi-automatic volumetric filling machine

TYPICAL FEATURES

- Solid construction and easy to operate.
- High accuracy and reproducibility.
- Fully pneumatic operated (explosion proof in accordance with ATEX).
- Self-priming, filling directly out of a drum, tote or product hopper.



- Fast change to a different fill volume by means of 7 pre-set volumes.
- Easy to clean by means of an automatic rinse cycle and removeable filling cylinder.
- Movable frame with height adjustable working table executed in stainless steel.
- Easy to expand with feed- and discharge roll conveyor, sub-level filling lance, lid closer (pressing/crimping) or screw cap closer.



**PART OF
GEURTSSEN
GROUP**

Gemini Techniek B.V.

Metaalstraat 22
7483 PD Haaksbergen
The Netherlands

+31 (0)53 428 3000
info@gemini-techniek.com
www.gemini-techniek.com

VOLUMETRIC FILLING METHOD

The filling machines are based on a vertical placed self-priming dosage cylinder. A piston is vertically moving inside a cylinder. The stroke length and the diameter of the piston determine the fill volume. With a multiple stroke counter, larger fill volumes can be realised.

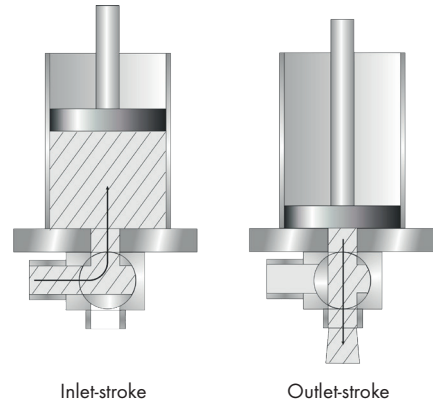

GemiFill S with sub-level filling lance and lid crimper.

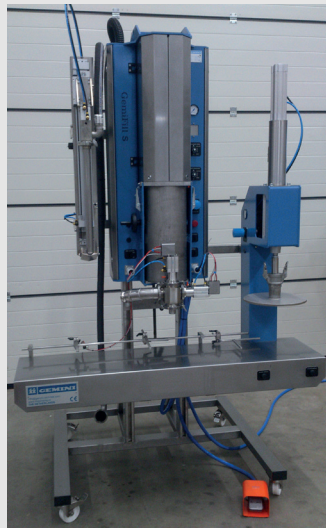

GemiFill S with sub-level filling lance and lid presser.

OPTIONAL SET-UP

The GemiFill S filling machine can be extended with the following options:

- Feed- and discharge roll conveyor.
- Sub-level filling lance.
- Lid closing device.
- Screw cap closer.
- Multiple stroke counter.
- Stepless volume adjustment.

Other options upon request.

TECHNICAL SPECIFICATIONS

Dimensions :	Approx. 2.500 x 1.200 x 1.200 mm (HxWxD).
Materials of construction :	All wetted parts made of stainless steel and PTFE.
Air pressure :	6 - 8 bar.
Filling method :	Volumetric.
Accuracy of fill :	Deviation < 0,5%.
Volume range :	Model S-2½ 125 ml. - 2½ ltr.
(Available models)	Model S-7½ 250 ml. - 7½ ltr.
	Model S-12½ 500 ml. - 12½ ltr.
	Model S-20 1 ltr. - 20 ltr.
	Upon request different volume ranges possible.